

Introduction

Thank you for using our product. In order to use the product correctly, please read this instructions before use. After reading, please keep this instructions when the user may use at any time.

Operational safety warnings

- Disassemble or fill oil to the machine may cause malfunction.
- Tap or fall (intensive impact) may damage parts and properties of the cleaver.
- The cleaver blade is sharp. Personal injury can result from contact with the blade.
- The fiber and fragment of the fiber is extremely sharp and dangerous, please clear them away as soon as possible.
- Properly place the fiber fragment, a special collector is recommended.
- If there is malfunction or abnormal, please stop using and contact the technical support team of our company. Do not disassemble or refit by yourself.

1

Important: If the safety operating instruments are not followed, it may cause damages to the human body and product.

Production description

Specification	
Applicable type	Single fiber and ribbon fiber
Cladding diameter	125µm
Cleaved length	Single fiber: 8~20mm / Ribbon fiber: 10mm
Applicable fiber cable	Single: 250µm, 900µm, 3.0mm fiber cable and flat cable Ribbon: 2~12 ribbon fiber cable
Size	62H x 64W x 74D mm
Weight	341g

2

Package



Optional accessories

Optional accessories	
Blade	B77
Fiber fixture	FH-SOC (exclusive for fusion welding joint) FH-12R (ribbon fiber -12 cores)

Operating method

- Place the fiber into the groove of the fixture.

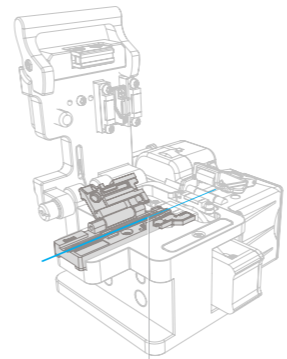

Single core optical fiber fixture

3

- Place the fiber into the groove of the fixture.

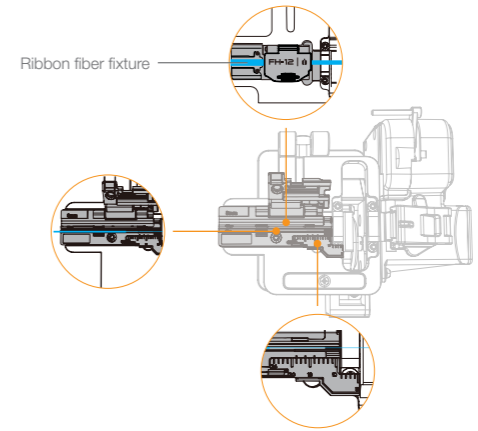

- Example of the cleaved length



Note: if the cutting length is 16mm, align the coating edge and the 16mm scale mark of the fixture, and keep the bare optical fiber in the groove.

- After examination, close the fixture cover and the upper cover of the cleaver. Then the fiber will be cut off and the cleaved fibers will automatically fall in to the collector.

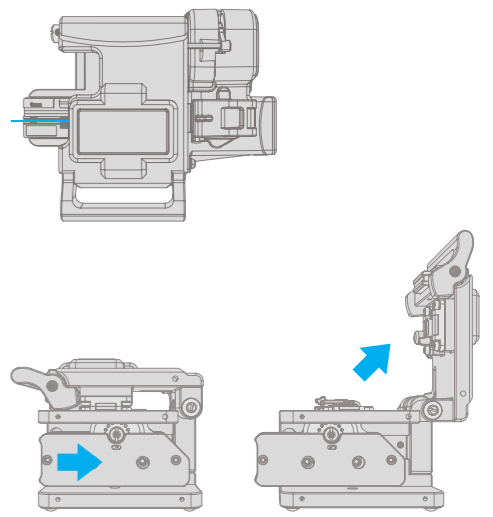

Note: Manually cutting, automatically returning!

next >

Installation and disassemble of the collector

- Align 1 to 4 and insert the collector into the machine, and spin tight the screw at 2, 3 and 4 in order to fix the collector onto the cleaver.

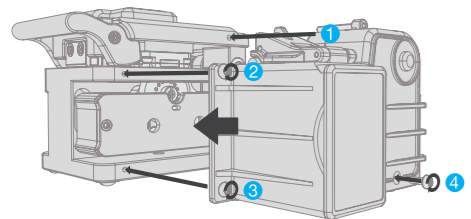

- Spin loose the screws at 1, 2, 3 and take off the collector.

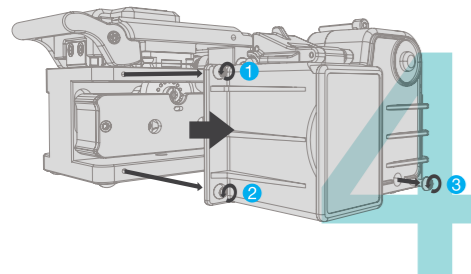

Trouble Shooting



Wrong cleaved angle



Spur left



Smashed core



Dust on the surface of the bare fiber

- The fiber is not well placed.
 - Please horizontally place the fiber.
- The blade is placed too high.
 - Please adjust the height of the blade.
- There is dust or other objects on the rubber cushion or the fixture.
 - Please clean the rubber cushion or the fixture.
- There is dust or other objects on the fiber.
 - Please strip the coating of the fiber again, and then clean the fiber with alcohol.

Note: If the bad cutting is repeatedly occurred, please contact the technical support team of our company.

Adjustment the blade

- Use T8 wrench to spin loose the screw at place 1, insert into place 2 with toll and spin anticlockwise to the next scale mark, and then spin tight the screw at place 1.
- Use T8 wrench to spin loose the screw at 3 and 4.

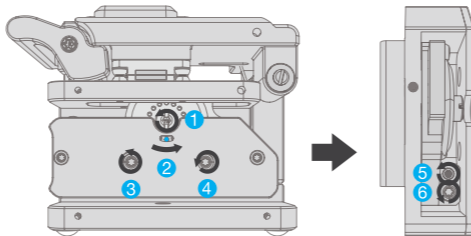

- Spin screw 6 on the left to adjust the fixing screw 5 to change the height of the blade.
- After adjustment, spin tight the fixing screw 3 and 4 successively, at the same time, spin tight M3 to adjust T8 box spanner 6 beside the fixing screw.

Daily cleaning

- To maintain the cutting function of the fiber cleaver, please clean it as soon as possible after use.
- Use dehydrated alcohol and cotton swab to clean the places according to the below picture.
- The grooves of the fiber fixture also need to be cleaned.

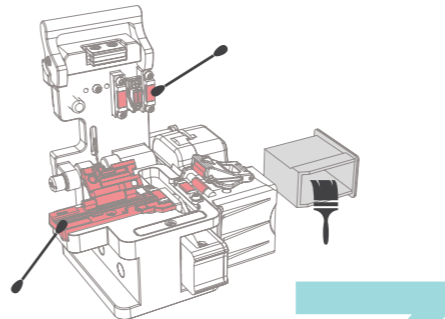

Please visit us on Facebook
www.facebook.com/innoinstrument

www.innoinstrument.com

Quick Manual

INNO
INSTRUMENT | You dream,
We DESIGN

Vicom

Vicom Australia
1064 Centre Rd
Oakleigh South Vic
3167 Australia
1300 360 251
info@vicom.com.au
www.vicom.com.au

Vicom New Zealand
Grd Floor, 60 Grafton
Rd Auckland 1010
New Zealand
+64 9 379 4596
info@vicom.co.nz
www.vicom.co.nz